

• *VB-FullAir*



The Fiat Ducato X250



with VB-FullAir rear-axle air-suspension

www.vbairsuspension.com

The Fiat Ducato X250 also available with VB-FullAir rear-axle air-suspension



The Fiat Ducato is available with rear axle air suspension. The Ducato is extremely suited for the use of air suspension systems and our VB-Full-Air-2C is available for new and used vehicles. This newly developed rear axle air suspension, from VB-Airsuspension, is available as an after-market option through the VB-Airsuspension dealers and Fiat network.



Market circumstances

The Fiat Ducato will be used for a wide range of individual needs and market circumstances where air-suspension is essential. For example: passenger transport, disabled persons transport, rescue vehicles, motorhomes, car transporters and for the transport of shock-sensitive products. For these and more usages, and individual needs, our VB-FullAir-2C is the right solution.

VB-FullAir 2C system

The VB-FullAir, a full-air rear-axle air-suspension, has an electronic system named VB-ASCU (VB-Air Suspension Control Unit), which automatically monitors and adjusts the height level of the vehicle. This constant monitoring and adjusting (independent of the load, in the longitudinal and lateral direction and relatively independent of centre gravity height) will automatically contribute to a safe vehicle behaviour and a better comfort. The vehicle may not be overloaded.

Changing height

The vehicle level can be changed manually with the standard remote control when the vehicle stands still; therefore lowering of the chassis/ load platform is one of the systems standard possibilities.

Software

The electronic part of the rear axle air suspension is compatible with the vehicle's main electrical system. Various software variants create the possibility to adapt the VB-Full-Air-2C air-suspension to the specific use of the vehicle.

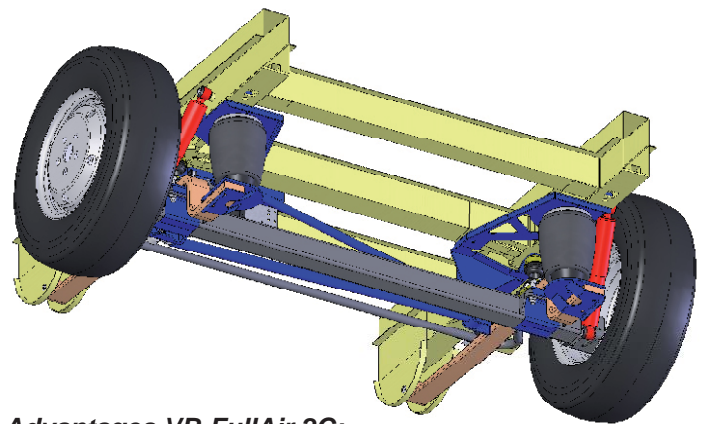

Advantages VB-FullAir 2C:

- Improved suspension comfort
- Constant ride height
- Improved road handling and stability
- Increased protection of vulnerable / sensitive goods
- Less impact for passengers
- Kneeling facility
- Less wear of tyres / brakes
- Environmentally friendlier, less CO2 emission

Supply and service

The air-suspension for the Fiat Ducato can be supplied and serviced by VB-Airsuspension dealers and through the Fiat dealer organisation.

Technical specifications:	
Standard ride height (Unloaded with original steel suspension)	720 mm
Ride height with VB-FullAir	675 mm
Highest position (0-5km/h)	+ 45 mm
Lowest position (0-5km/h)	- 65 mm
Chassis height at the rear axle.	

For more information: info@vbairsuspension.com



© 01-2010