



VB-FULLAIR-4C

making everyday smoother



airsuspension



- Increased comfort • Better driveability • More safety



PEUGEOT BOXER
FIAT DUCATO
CITROËN JUMPER

X250 Al-Ko chassis 2006 >

PRODUCT SHEET

PRODUCT SHEET

Airsuspension systems for the higher class vehicles have become a commonly specified option in recent years. VB-Airsuspension in Holland has a solution for motor homes with an Al-Ko chassis in the form of an integrated 4-Corner air-suspension system. This VB-FullAir air-suspension increases comfort and drivability. For driver and passengers of the motor home is this a welcome solution.

VB-FullAir-4C system

The VB-FullAir, a full-air air-suspension, has an electronic system named VB-ASCU (VB-Air Suspension Control Unit), which automatically monitors and adjusts the ride-height of the vehicle. This constant monitoring and adjusting (independent of the load, in the longitudinal and lateral direction, regardless of the centre of gravity) will automatically contribute to safer vehicle behaviour and improved comfort.

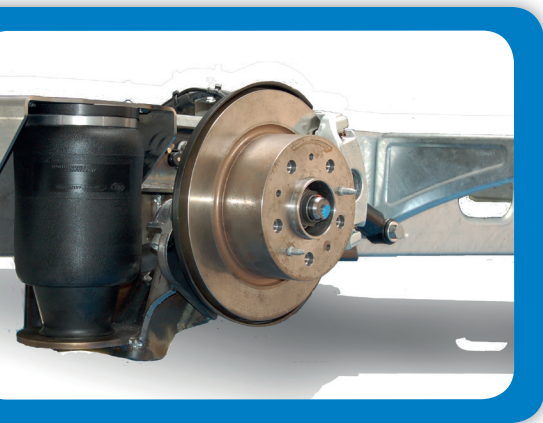

Software

The electronic part of the rear axle air suspension is compatible with the vehicle's main electrical system. Various settings can be commanded by the standard handheld remote. For example; lifting the chassis for more driveheight to enter a ferry. Tilt function to empty a watertank, raise or lower front, raise or lower rear. As extra option is a autolevel function available.

For the fitting of the air-suspension kit the Fiat & Citroen factory option 081 and Peugeot option J108 is required. This air-suspension kit suits on a Supertiefrahmen chassis of ALKO. With the fitting of the air-suspension, the track width of the rear axle will be increased by 30mm. By fitting the air-suspension kit, the maximum GVW or the maximum axle load is not altered.

Dealer:

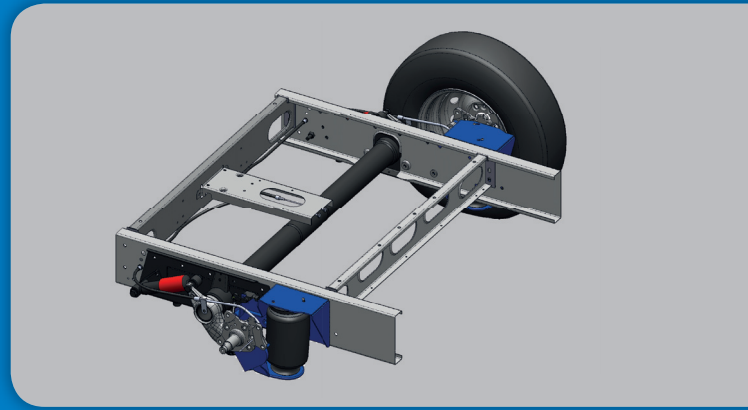

Advantages VB-FullAir-4C:

- Improved suspension comfort
- Constant ride height
- Improved road handling and stability
- Increased protection of vulnerable / sensitive goods
- Less impact for passengers
- Kneeling facility
- Less wear of tyres / brakes
- Environmentally friendlier, less CO² emission

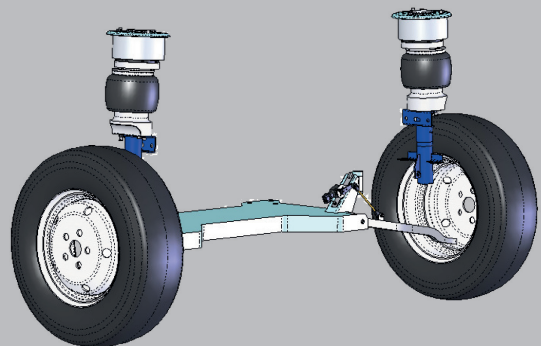

Technical specifications:*

| | Front | Rear |
|--------------------------------|---------|----------|
| Ride height with VB-FullAir-4C | 785 mm | 484 mm |
| Highest position (0-5km/h) | + 70 mm | + 29 mm |
| Lowest position (0-5km/h) | - 95 mm | - 103 mm |

* All the measurements are in mm, measured above the centre-line of the rear axle on a standard chassis, with tyre size 215/70R15 and a rear axle load of 1900kg. Therefore a tyre compression of 30mm is included.